

Hydraulic Gear Pump Model GP-F25



Constructed of an aluminium center section and cast iron end plates, model GP-F25 is a high pressure hydraulic gear pump with 10 displacement sizes from 1.34 - 5.43 in³/rev (22 - 89 cm³/rev). The standard mounting flange is a SAE B - 2-bolt with a 7/8" diameter straight shaft and 1/4" key.

Technical Specifications

Model	Displacement in ³ (cm ³) / rev	Pressure psi	Speed rpm		Weight Lbs.
			Rated	Max	
GP-F25-22	1.34 (22)	3625	2000	3000	19.35
GP-F25-26	1.57 (26)	3625	2000	3000	19.55
GP-F25-34	2.07 (34)	3625	2000	3000	20.20
GP-F25-39	2.38 (39)	3625	2000	3000	20.65
GP-F25-43	2.62 (43)	3625	2000	2800	20.85
GP-F25-51	3.11 (51)	3625	2000	2800	21.50
GP-F25-60	3.84 (60)	2900	1500	2800	22.25
GP-F25-70*	4.27 (70)	2900	1500	2500	22.75
GP-F25-78*	4.76 (78)	2900	1500	2300	23.50
GP-F25-89*	5.43 (89)	2600	1500	2000	25.00

Flow Rate (gpm) = Displacement (in³/rev) X Speed (rpm) / 231
Volumetric efficiency % ≥93

Recommended working conditions:

FILTRATION: 25 micron or better
OIL VISCOSITY: 7 - 700 cSt
INLET PRESSURE: 12 - 32 psi absolute
OIL TEMPERATURE: -25° - 80° C (-12° - 175° F)
AMBIENT -22° - 55° C (-8° - 130° F)

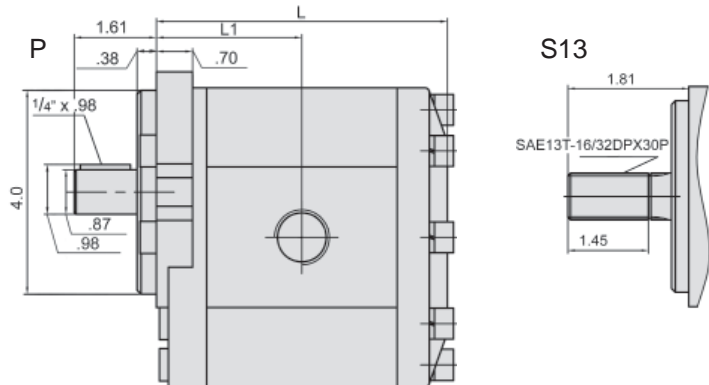
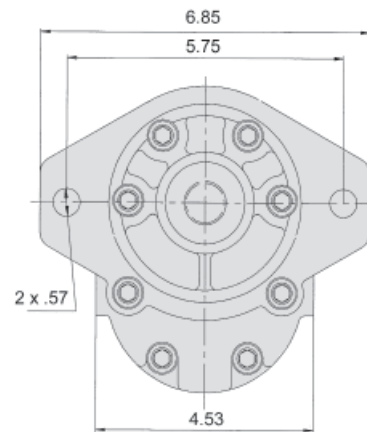

Installation Data

Model	L	L1	Ports	
			In	Out
GP-F25-22	5.16"	2.60"	SAE-16	SAE-12
GP-F25-26	5.27"	2.63"	SAE-16	SAE-12
GP-F25-34	5.47"	2.71"	SAE-16	SAE-12
GP-F25-39	5.62"	2.79"	SAE-16	SAE-12
GP-F25-43	5.78"	2.87"	SAE-16	SAE-12
GP-F25-51	5.98"	2.99"	SAE-16	SAE-12
GP-F25-60	6.22"	3.11"	SAE-16	SAE-12
GP-F25-70*	6.53"	3.22"	SAE-20	SAE-16
GP-F25-78*	6.73"	3.34"	SAE-20	SAE-16
GP-F25-89*	6.93"	3.46"	SAE-20	SAE-16

Ordering Example:

Category: **GP** - Series: **F25** - Displacement: **34** - Drive Shaft: **P** - Rotation: **C**

Category	Series	Displacement (see chart)	Drive Shaft**	Rotation
Gear Pump	F25 Series SAE "B" Mount	22/26/34/39/43/51 60/70*/78*/89*	P = 7/8" dia. Straight S13 = 13-tooth Spline	C = Clockwise A = Counter-Clockwise (viewed from shaft end)

* Special Order.

** Additional seal and shaft options available. Please consult factory.

Seal kits for F25 gear pumps are available. See page 126 for details.