

Hydraulic Gear Pump Model GP-F10

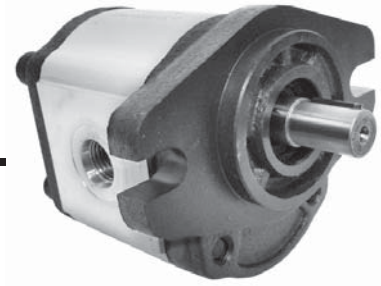

Constructed of an aluminium center section and cast iron end plates, model GP-F10 is a high pressure hydraulic gear pump with 8 displacement sizes from 0.07 - 0.48 in³/rev. (1.3 - 8.0 cm³/rev). The standard mounting flange is a SAE AA - 2 bolt; standard ports are SAE-8 inlet and SAE-6 outlet; and the drive shaft is a 1/2" diameter straight shaft with 1/8" key.

Recommended working conditions:

FILTRATION: 25 micron or better OIL VISCOSITY: 7 - 700 cSt
 INLET PRESSURE: 12 - 32 psi absolute OIL TEMP: -25° - 80°C (-12° - 175°F)
 AMBIENT TEMP: -22° - 55°C (-8° - 130°F)

Technical Specifications

Model	Displacement in ³ (cm ³) / rev	Pressure psi	Speed rpm		Weight Lbs.
			Rated	Max	
GP-F10-13	0.07 (1.3)	3625	2000	5000	2.02
GP-F10-20	0.12 (2.0)	3625	2000	5000	2.31
GP-F10-27	0.16 (2.7)	3625	2000	5000	2.68
GP-F10-34	0.20 (3.4)	3625	2000	5000	2.99
GP-F10-41	0.25 (4.1)	3625	2000	4000	3.34
GP-F10-51	0.31 (5.1)	3625	2000	4000	3.78
GP-F10-61	0.37 (6.1)	3625	2000	4000	4.18
GP-F10-80	0.48 (8.0)	3480	2000	4000	5.01

Flow Rate (gpm) = Displacement (in³/rev) X Speed (rpm) / 231
 Volumetric efficiency % ≥93

Installation Data

Model	L	L1	Ports	
			In	Out
GP-F10-13	3.23"	1.65"	SAE-8	SAE-6
GP-F10-20	3.30"	1.69"	SAE-8	SAE-6
GP-F10-27	3.39"	1.73"	SAE-8	SAE-6
GP-F10-34	3.46"	1.77"	SAE-8	SAE-6
GP-F10-41	3.54"	1.81"	SAE-8	SAE-6
GP-F10-51	3.66"	1.87"	SAE-8	SAE-6
GP-F10-61	3.78"	1.93"	SAE-8	SAE-6
GP-F10-80	3.97"	2.01"	SAE-8	SAE-6

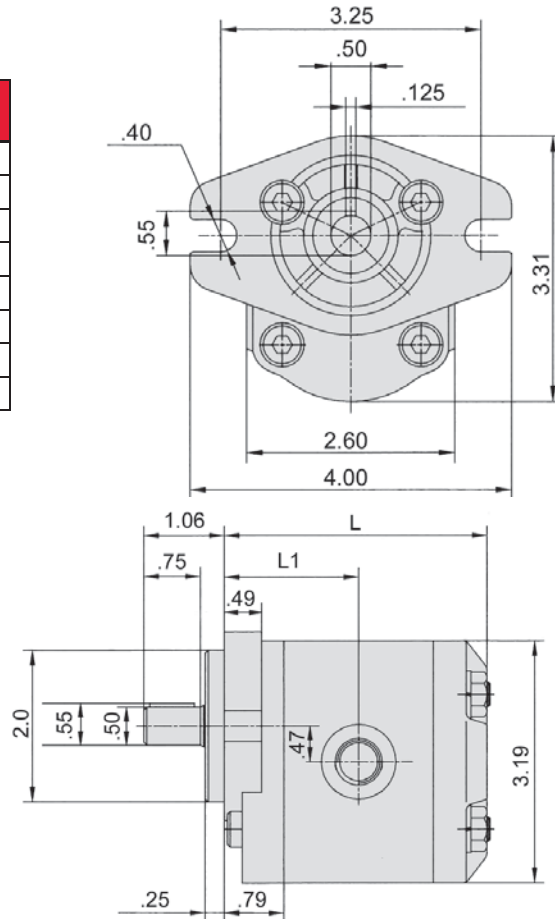

Ordering Example:

Category Series Displacement Drive Shaft Rotation Options
GP - **F10** - **20** - **P** - **C** -

Category	Series	Displacement (see chart)	Drive Shaft*	Rotation	Options
Gear Pump	F10 Series SAE "AA" Mount	13/20/27/34 41/51/61/80	P = 1/2" dia. Straight	C = Clockwise A = Counter-Clockwise (viewed from shaft end)	BB* = Rear Ports Y* = Relief Valve

* Special Order.

** Additional seal and shaft options available. Please consult factory.

Seal kits are available for F10 gear pumps. See page 126 for details.