

OVERALL DIMENSIONS

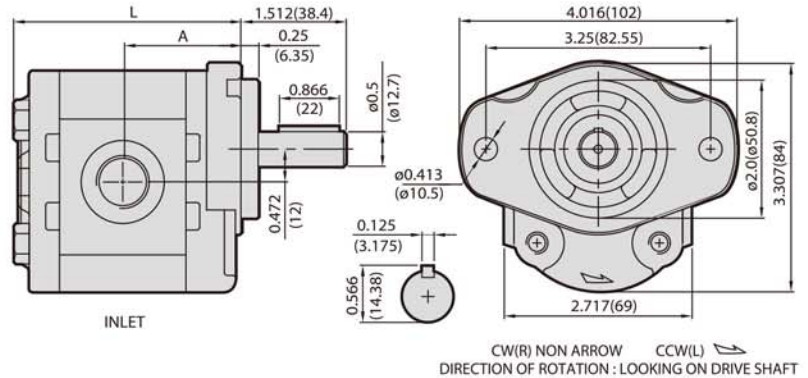

ORDERING EXAMPLE

For Example **1** **A** **G** **2** **U**

SERIES TYPE FLANGE SHAFT PORT DISPL. ROTATION

If you need pump with displ.0.31 c.i.r and rotation is cw, the model number is: **1AG2U05R**

PERFORMANCE DATA

MODEL	DISPLACEMENT		PRESSURE psi(MPa)		RPM RANGE	DIMENSIONS inch(mm) SUITABLE "G", "C", "E" MOUNTING FLANGES		WEIGHT	
	c.i.r	cm <sup>3</sup> /r	CONTINUOUS	MAX.		A	L	Kg	LBS
05	0.04	0.6	3000(21)	3600(25)	600   4000	1.626(41.3)	3.114(79.1)	1.09	2.40
01	0.08	1.3	3000(21)	3600(25)		1.655(42.0)	3.173(80.6)	1.10	2.42
02	0.12	2.0	3000(21)	3600(25)		1.694(43.0)	3.252(82.6)	1.14	2.51
27	0.16	2.7	3000(21)	3600(25)		1.734(44.0)	3.331(84.6)	1.18	2.60
35	0.21	3.4	3000(21)	3600(25)		1.773(45.0)	3.409(86.6)	1.21	2.66
04	0.25	4.1	3000(21)	3600(25)		1.813(46.0)	3.488(88.6)	1.25	2.75
05	0.31	5.1	3000(21)	3600(25)	600   (* )2500	1.872(47.5)	3.606(91.6)	1.30	2.86
06	0.37	6.1	3000(21)	3600(25)		1.931(49.0)	3.724(94.6)	1.35	2.97
07	0.45	7.4	2850(20)	3300(23)		2.009(51.0)	3.882(98.6)	1.41	3.10
09	0.55	9.1	2550(18)	2850(20)		2.108(53.5)	4.079(103.6)	1.49	3.28
11	0.67	11.0	2300(16)	2550(18)		2.226(56.5)	4.315(109.6)	1.58	3.48
13	0.82	13.5	2300(16)	2550(18)		2.364(60.0)	4.591(116.6)	1.69	3.72

\*More than 2500 qualified per applications.

DRIVE SHAFTS

SUITABLE FOR G FLANGE

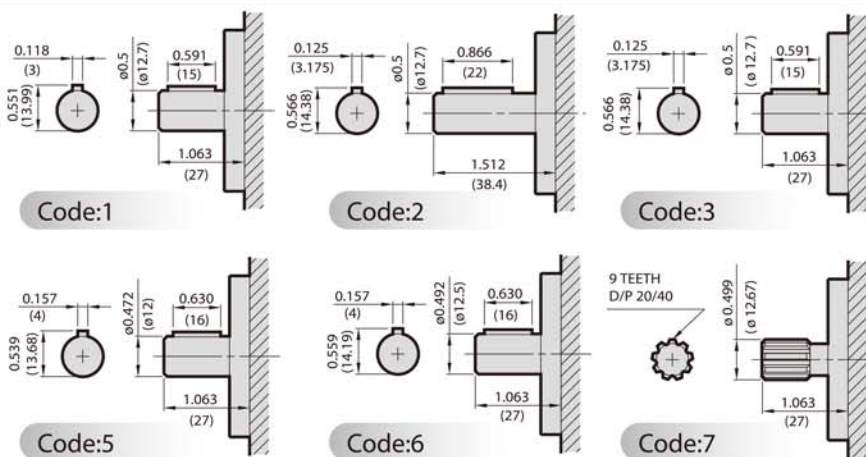

DRIVE SHAFTS

SUITABLE FOR K L FLANGE

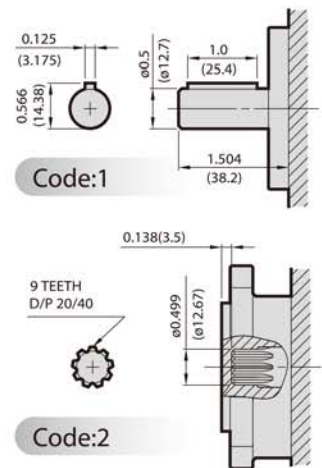

SUITABLE FOR C E FLANGE

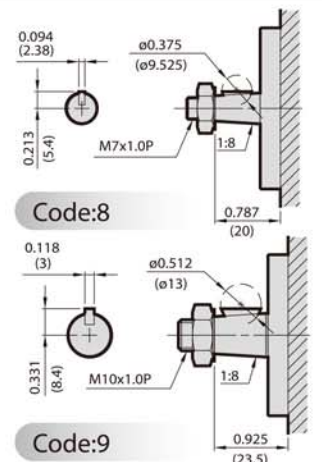

## ■ MOUNTING FLANGES

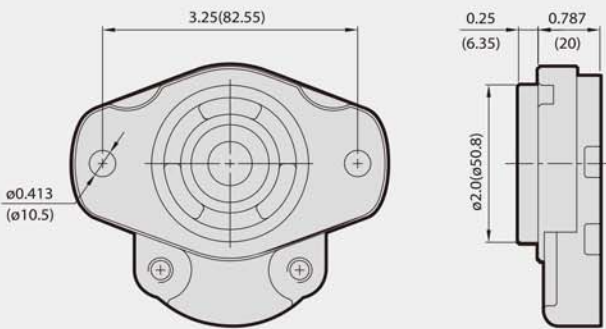

Code:G

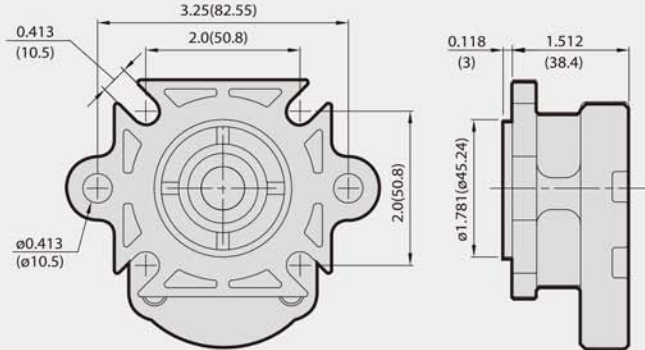
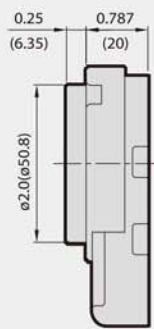

Code:K- SAE AA-2 Bolts & 4F17-4 BOLTS  
Code:L- 4F17-4 BOLTS

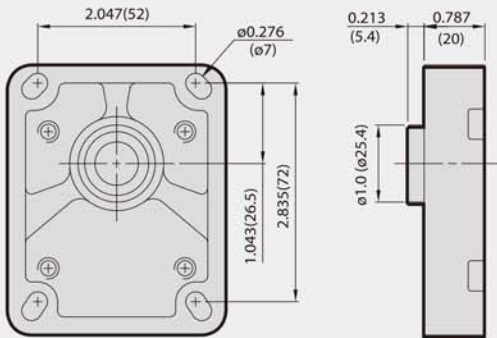

Code:C

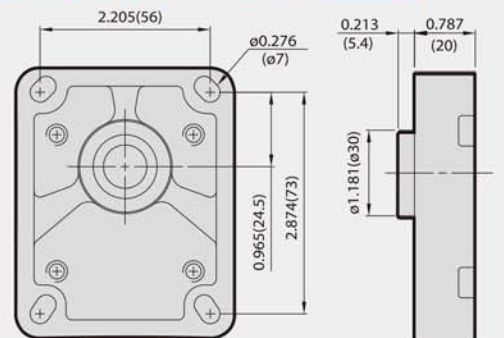

Code:E

## ■ PORTS

### UNF

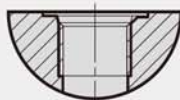

Code	From "05" to "06"		From "07" to "13"	
	INLET	OUTLE	INLET	OUTLET
U	UNF# 8 3/4"-16	UNF# 6 9/16"-18	UNF# 10 7/8"-14	UNF# 8 3/4"-16

### PT 、 NPT 、 BSPF

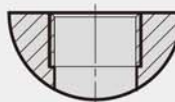

Code	From "05" to "06"		From "07" to "13"	
	INLET	OUTLE	INLET	OUTLET
P	PT 1/2"	PT 3/8"	PT 3/4"	PT 1/2"
N	NPT 1/2"	NPT 3/8"	NPT 3/4"	NPT 1/2"
B	BSPF 1/2"	BSPF 3/8"	BSPF 3/4"	BSPF 1/2"

### FLANGE (SQUARE)

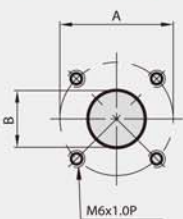

Code	From "05" to "13"	
	INLET & OUTLET	
F	A	B
	0.181 (4.7)	0.511 (13.0)

### FLANGE (DIAMOND)

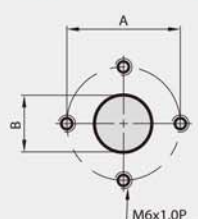

Code	From "05" to "13"	
	INLET & OUTLET	
E	A	B
	0.181 (4.7)	0.511 (13.0)



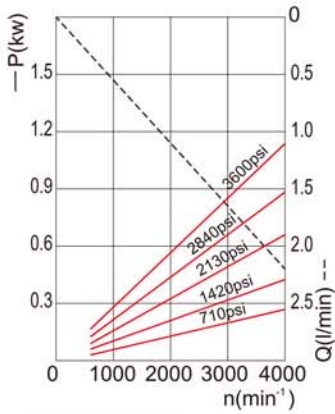
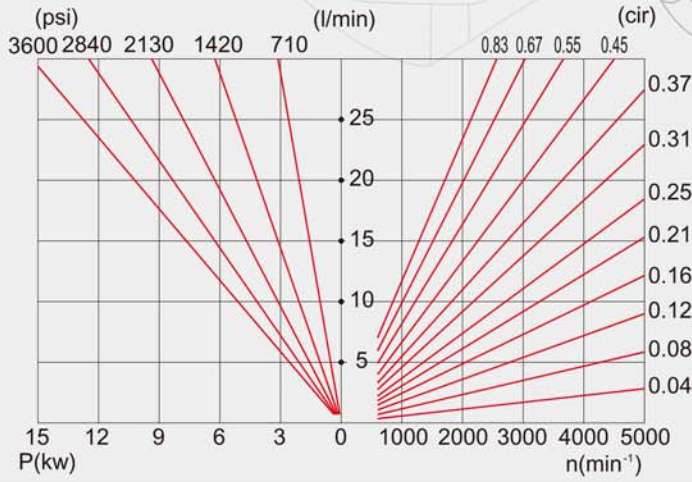

MODEL:05

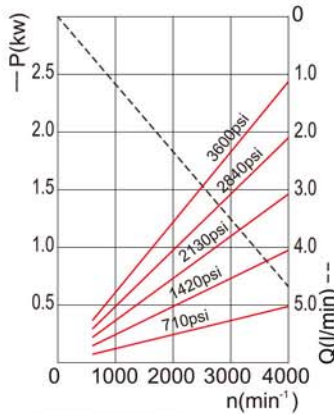

MODEL:01

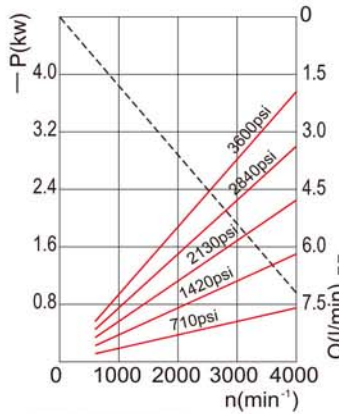

MODEL:02

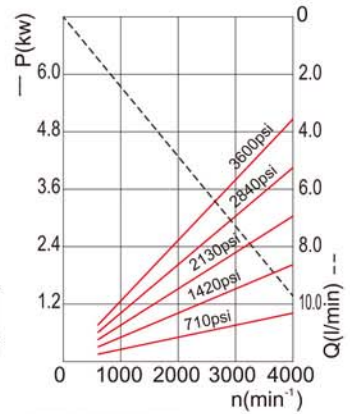

MODEL:27

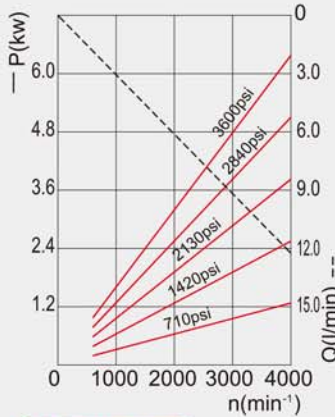

MODEL:35

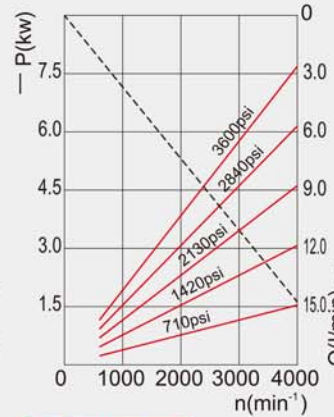

MODEL:04

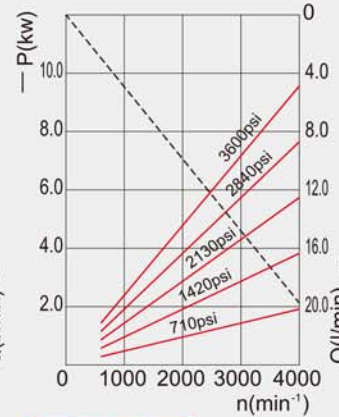

MODEL:05

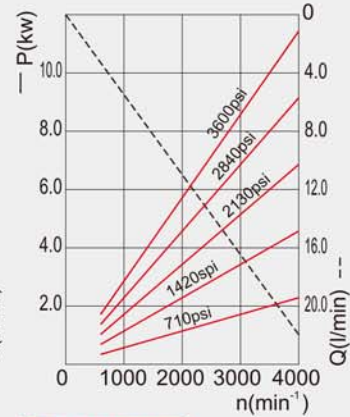

MODEL:06

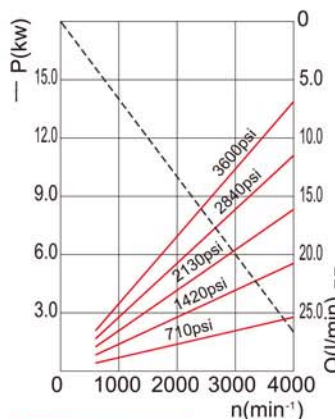

MODEL:07

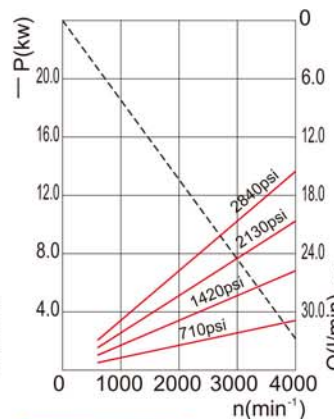

MODEL:09

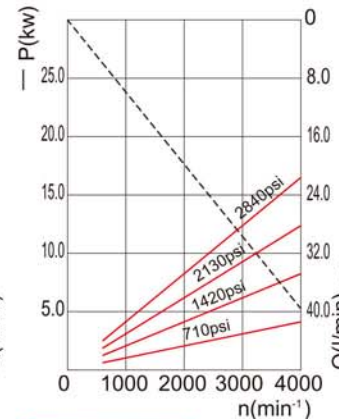

MODEL:11

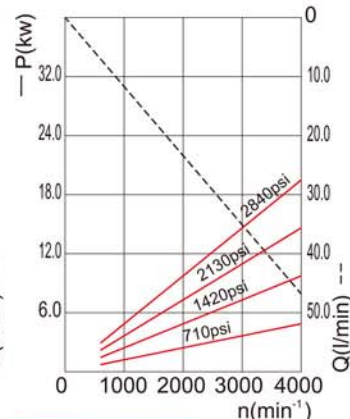

MODEL:13