

## ■ Poppet Type Directional Valves

These are Solenoid Operated Directional Valves of No Leak Type developed with the aim of responding the demand of the age including energy saving. Because these valves are of no leak type they allow the low viscosity hydraulic fluids to be used as well as the circuit construction which cannot be used by the conventional spool type directional valves because of too much internal leak of pressure oil. The use of the low viscosity hydraulic fluids reduces the pressure loss which can arise from the passage resistance of the hydraulic fluids, leading to the system energy saving.

## ■ Poppet Type Solenoid Operated Directional Valves

- High Response High Reliability

Because these valves are of poppet type, there is no overlap, high response can be achieved. At the same time, hydraulic lock is eliminated.

- No Leak

Sheet type seal has been adopted and internal leak is greatly reduced.

- ISO Comformant Mounting Surface

Because the mounting surface conforms to ISO 4401-AB-03-4-A, there is an interchangeability with the conventional valves. This makes it possible to use these valves in combination with 01 Series Modular Valves.

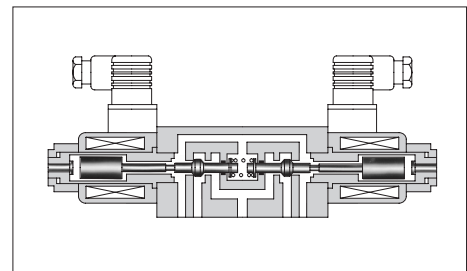

### ■ Specifications

Model Numbers	Max. Flow L/min (U.S.GPM)	Max. Operating Pressure MPa (PSI)	Max. T-Line Back Pressure MPa (PSI)	Max. Changeover Frequency min <sup>-1</sup> {Cycles/Min}	Internal leakage cm <sup>3</sup> /min (cu. in./min)	Approx. Mass kg (lbs.)	Graphic Symbols
DSL-G-01-3-C-*N-11	16 (4.2)	31.5 (4570)	16 (2320)	240	Or Less 0.5 <sup>★1</sup> (.03)	1.9 (4.2)	
DSL-G-01-3-O-*N-11							
DSL-G-01-4-O-*N-11					Or Less 1 <sup>★2</sup> (.06)	3.7 (8.2)	

★1. This is the leakage towards "T" port in A port block at "P" port pressure 14 MPa (2030 PSI).

★2. This is the leakage towards "T" port in A•B port block at "P" port pressure 14 MPa (2030 PSI).

### ■ Solenoid Ratings

Electric Source	Coil Type	Frequency (Hz)	Voltage (V)		Current & Power at Rated Voltage	
			Source Rating	Serviceable Range	Holding (A)	Power (W)
DC (K Series)	D12	—	12	10.8 - 13.2	2.45	29
	D24	—	24	21.6 - 26.4	1.23	
AC→DC Rectified	R100	50/60	100	90 - 110	0.33	29
	R200	50/60	200	180 - 220	0.16	

**Model Number Designation**

F-	DSLGL	-01	-4	-O	-D24	-N	-11	*
Special Seals	Series Number	Valve Size	Number of Port	Function	Coil Type	Type of Electrical Conduit Connection	Design Number	Design Standards
<b>F:</b> Special Seals for Phosphate Ester Type Fluids (Omit if not required)	<b>DSLGL:</b> Poppet Type Solenoid Operated Directional Valve (Sub-plate Mtg.)	<b>01</b>	<b>3:</b> 3 Port	<b>O:</b> Normally Open <b>C:</b> Normally Closed	DC <b>D12, D24</b>	<b>N:</b> Plug-in Connector	<b>11</b>	Refer to ★
			<b>4:</b> 4 Port	<b>O:</b> Normally Open	AC→DC <b>R100</b> <b>R200</b>			

★ Design Standards: None ..... Japanese Standard "JIS" and European Design Standard 90 ..... N. American Design Standard

**Sub-plate**

Piping Size	Japanese Standard "JIS"		European Design Std.		N. American Design Std.		Approx. Mass kg (lbs.)
	Sub-plate Model No.	Thread Size	Sub-plate Model No.	Thread Size	Sub-plate Model No.	Thread Size	
1/8	DSGM-01-31	Rc 1/8	DSGM-01-3180	1/8 BSP.F	DSGM-01-3190	1/8 NPT	0.8 (1.8)
1/4	DSGM-01X-31	Rc 1/4	DSGM-01X-3180	1/4 BSP.F	DSGM-01X-3190	1/4 NPT	0.8 (1.8)
3/8	DSGM-01Y-31	Rc 3/8	—	—	DSGM-01Y-3190	3/8 NPT	0.8 (1.8)

● Sub-plates are available. Specify the sub-plate model number from the table above. When sub-plates are not used, the mounting surface should have a good machined finish.

**Mounting Bolts**

Four socket head cap screws in the table below are included.

Descriptions	Socket Head Cap Screw (4 pcs.)	Tightening Torque
Japanese Standard "JIS" European Design Standard	M5 × 45 Lg.	5-7 Nm (44-62 in. lbs.) [Applicable to working pressure more than 25 MPa (3630 PSI) : 6-7 Nm (53-62 in. lbs.)]
N. American Design Standard	No. 10-24 UNC × 1-3/4 Lg.	

**Instructions**

● **Mounting**

No mounting restrictions for any models.

● **Solenoid Shifting**

On double solenoid valves do not energise both at the same time.

● **Valve Tank Port**

Avoid connecting the valve tank port to a line with possible surge pressure.

● **Operating Force by Manual Actuator**

Take care as the operating force by the manual actuator increases in proportion to the tank line back pressure. (See the graph right.)

**Operating Force by Manual Actuator**

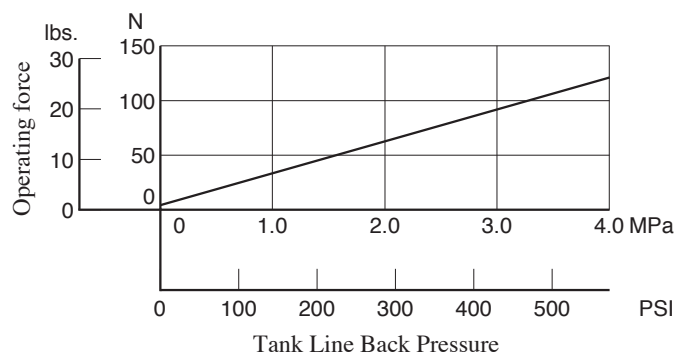

## Pressure Drop

Hydraulic Fluid: Viscosity 35 mm<sup>2</sup>/s (164 SSU), Specific Gravity 0.850

### 4 Port Valve

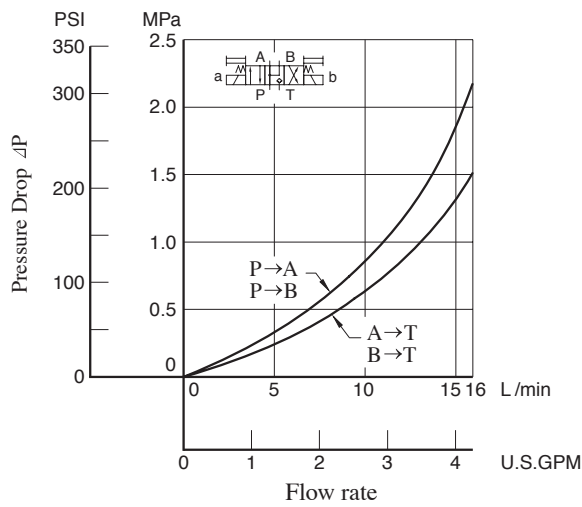

### 3 Port Valve

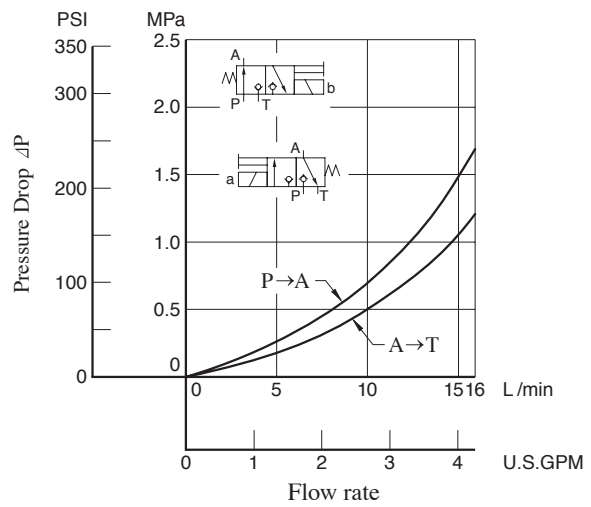

- For any other viscosity, multiply the factors in the table below.

Viscosity	mm <sup>2</sup> /s	15	20	30	40	50	60	70	80	90	100
	SSU		77	98	141	186	232	278	324	371	417
Factor		0.81	0.87	0.96	1.03	1.09	1.14	1.19	1.23	1.27	1.30

- For any other specific gravity (G'), the pressure drop (ΔP') may be obtained from the formula below.

$$\Delta P' = \Delta P (G'/0.850)$$

## Changeover Time

Changeover time varies according to hydraulic circuit of the model actually used and conditions. An example of measurement is given in the figure below.

### Test Circuit and Conditions

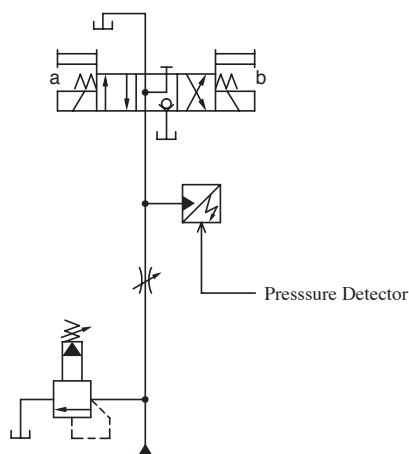

Pressure: 21 MPa (3050 PSI)  
 Flow Rate: 16 L/min (4.2 U.S.GPM)  
 Voltage: Rated voltage

### Result of Measurement

#### (DC Solenoid)

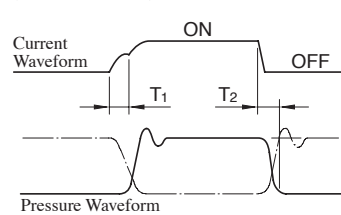

#### (AC→DC Rectified)

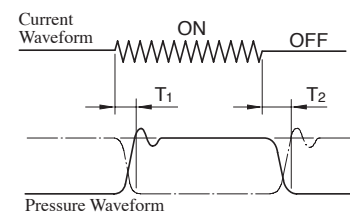

Note: Alternate long and short dash lines in the pressure waveform figures indicate the waveforms for Normally Closed Type 3 Port Valves.

Solenoid Type	Model Numbers	Time (ms)		Remarks
		T <sub>1</sub>	T <sub>2</sub>	
DC	DSL-G-01-4-O-D*	55	30	4 port valve, normally open
	DSL-G-01-3-O-D*	55	30	3 port valve, normally open
	DSL-G-01-3-C-D*	70	25	3 port valve, normally closed
AC→DC Rectified	DSL-G-01-4-O-R*	55	150	4 port valve, normally open
	DSL-G-01-3-O-R*	55	150	3 port valve, normally open
	DSL-G-01-3-C-R*	70	150	3 port valve, normally closed

■ 4 Port Valve

Mounting Surface:  
ISO4401-AB-03-4-A

● Normally Open: DSLG-01-4-O-\*-N-11/1190

**DIMENSIONS IN  
MILLIMETRES (INCHES)**

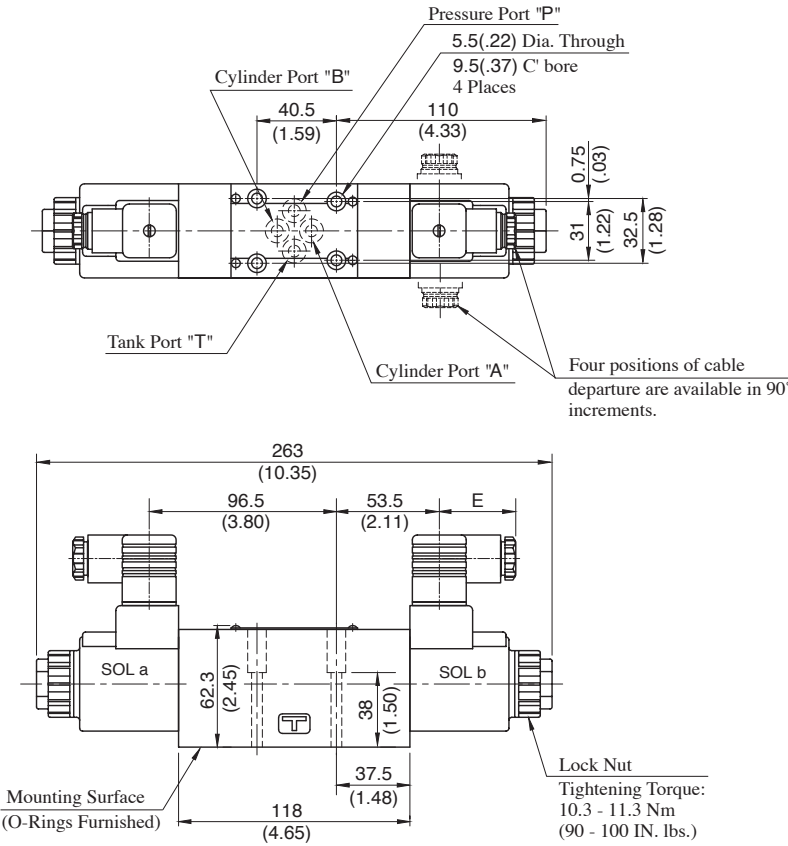

The connector can be moved to various positions by loosening the "Lock Nut". After location tighten "Lock Nut".

Cable Departure

Cable Applicable:

Outside Dia. .... 8-10 mm (.31 - .39 in.)  
Conductor Area ... Not Exceeding 1.5 mm<sup>2</sup>  
(.0023 Sq. in.)

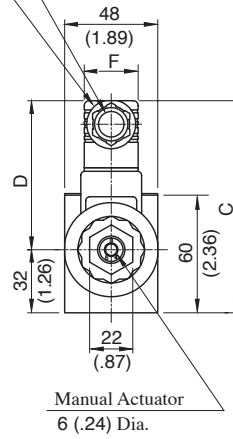

Model Numbers	Dimensions mm (Inches)			
	C	D	E	F
DSL-01-4-O-D*-N	108 (4.25)	64 (2.52)	39 (1.54)	27.5 (1.08)
DSL-01-4-O-R*-N	111 (4.37)	57.2 (2.25)	51 (2.01)	34 (1.34)

● The information on 3 Port Valves is provided in the [following page](#).

Note: For the valve mounting surface dimensions, see the dimensional drawing of the sharable sub-plate in [page 356](#).

Mounting Surface:  
ISO4401-AB-03-4-A

## 3 Port Valves

DIMENSIONS IN  
MILLIMETRES (INCHES)

### ● Normally Open Type: DSL<sub>G</sub>-01-3-O-\*<sub>-</sub>N-11/1190

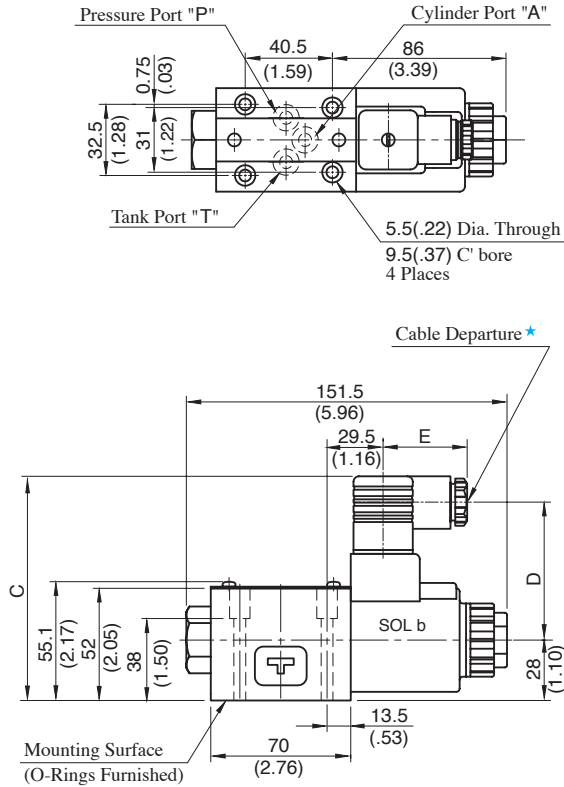

### ● Normally Closed Type: DSL<sub>G</sub>-01-3-C-\*<sub>-</sub>N-11/1190

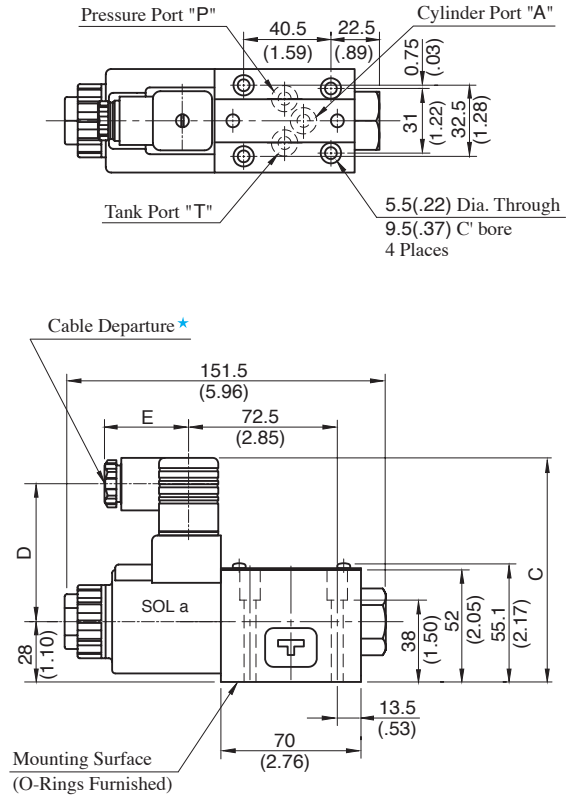

Model Numbers	Dimensions mm (Inches)		
	C	D	E
DSL <sub>G</sub> -01-3-* <sub>-</sub> D* <sub>-</sub> N	104 (4.09)	64 (2.52)	39 (1.54)
DSL <sub>G</sub> -01-3-* <sub>-</sub> R* <sub>-</sub> N	107 (4.21)	57.2 (2.25)	51 (2.01)

★ Cable departure position can be changed. See "4 Port Valves" in the previous page for the details.

Note: For the valve mounting surface dimensions, see the dimensional drawing of the sharable sub-plate in [page 356](#).

E

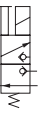

Poppet Type Solenoid Operated Directional Valves

■ List of Seals, Solenoid Ass'y and Connectors

**4 Port Valve**

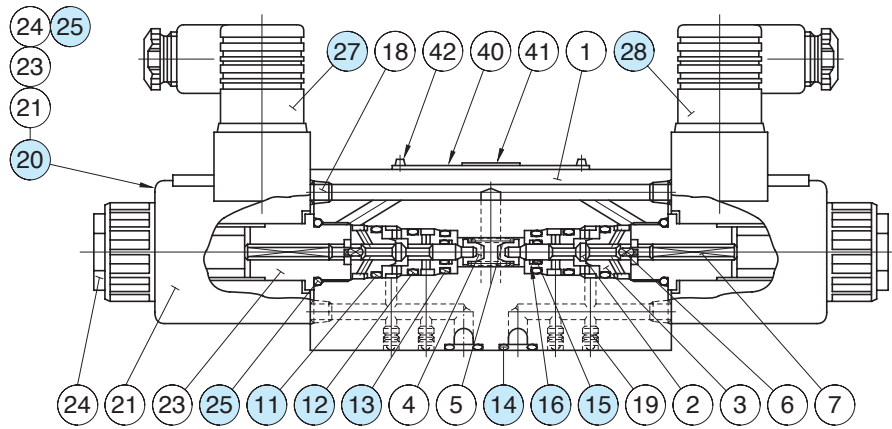

**3 Port Valve**

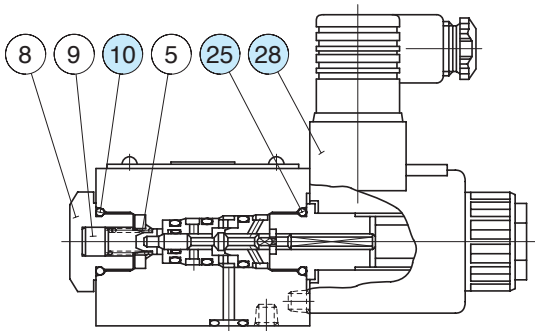

● List of Seals

Item	Name of Parts	Part Numbers	Quantity	
			4 Port Valve	3 Port Valve
10	O-Ring	SO-NB-P18	—	1
11	O-Ring	SO-NB-P14	2	1
12	O-Ring	SO-NB-P12	2	1
13	O-Ring	SO-NB-P11	2	1
14	O-Ring	SO-NB-P9	4	3
15	O-Ring	SO-NA-P5	2	1
16	Back Up Ring	2705-VK414322-8	2	1
25	O-Ring	SO-NB-P18	2	1

Note 1: O-Ring of item (25) are included in solenoid assembly.  
 2: When ordering the seals, specify the seal kit number from the table right.

● Change of supply voltage

The supply voltage can be changed by replacing the coil (21) only.

● List of Seal Kits

Valve Model Number s	Seal Kit Numbers
DSL G-01-3-O-* -N-11*	KS-DSL G-01-3-N-11
DSL G-01-3-C-* -N-11*	
DSL G-01-4-O-* -N-11*	KS-DSL G-01-4-N-11

● List of Solenoid Ass'y and Connectors

Valve Model No .	(20) Solenoid Ass'y No.	(21) Coil No.	(27) Connector No.	(28) Connector No.
DSL G-01-* -*-D12-N-11*	SD1L-12-N-20	C-SD1-12-N-60	GDM-211-A-11	GDM-211-B-11
DSL G-01-* -*-D24-N-11*	SD1L-24-N-20	C-SD1-24-N-60		
DSL G-01-* -*-R100-N-11*	SD1L-100-N-20	C-SR1-100-N-60	GDME-211-R-A-10	GDME-211-R-B-10
DSL G-01-* -*-R200-N-11*	SD1L-200-N-20	C-SR1-200-N-60		