

■ Proportional Electro-Hydraulic Flow Control and Relief Valves

These are proportional electro-hydraulic flow control valves having functions for controlling the direct electric current of metre-in type and for pressure control.

They are energy-saving valves for supplying the minimum pressure and flow required to operate actuators.

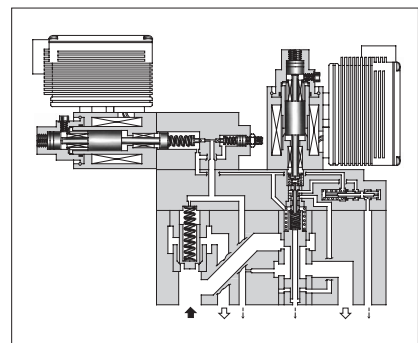
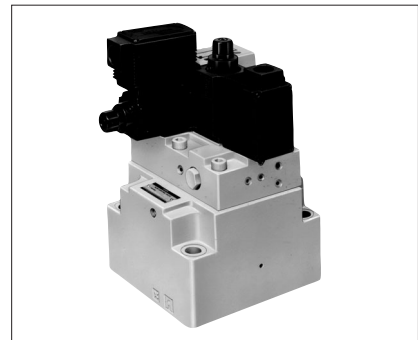

■ Specifications

Model Numbers		EHFBG-03- ₆₀ / ₁₂₅	EHFBG-06-250	EHFBG-10-500	
Description					
Max. Operating Pressure MPa (PSI)		24.5 (3550)	24.5 (3550)	24.5 (3550)	
Max. Flow					
L/min (U.S.GPM)		60: 60 (15.8) 125: 125 (33)	250 (66)	500 (132)	
Metred Flow Capacity					
L/min (U.S.GPM)		60: 1-60(.26-15.8) 125: 1-125(.26-33)	2.5-250 (.66-66)	5-500 (1.32-132)	
Min. Pilot Pressure MPa (PSI)		1.5 (215)	1.5 (215)	1.5 (215)	
Pilot Flow	at Normal	1 (.26)	1 (.26)	1 (.26)	
	at Transition	3 (.79)	4 (1.06)	6 (1.59)	
Differential Pressure MPa (PSI)		0.6 (85)	0.7 (100)	0.9 (130)	
Flow Controls	Hysteresis	3% or less			
	Repeatability	1%* or less			
	Input Signal	Max. Flow / 5 V DC			
	Coil Resistance	10 Ω			
	Supply Electric Power	24 V DC (21 to 28 V DC Included Ripple)			
	Input Impedance	10 kΩ			
	Power Input (Max.)	28 W			
Pressure Controls	Pres. Adj. Range	Adj. Range: C	1.2-15.7 (175-2275)	1.4-15.7 (200-2275)	1.5-15.7 (215-2275)
	MPa (PSI)	Adj. Range: H	1.4-24.5 (200-3550)	1.4-24.5 (200-3550)	1.5-24.5 (215-3550)
	Hysteresis	2% or less			
	Repeatability	1%* or less			
	Coil Resistance	10 Ω			
	Input Signal	Max. Operating Pres. / 5 V DC			
	Supply Electric Power	24 V DC (21 to 28 V DC Included Ripple)			
Input Impedance	10 kΩ				
Power Input (Max.)	28 W				
Output Signal	C : 5 V DC / 15.7 MPa (2275 PSI) H : 5 V DC / 24.5 MPa (3550 PSI)				
Ambient Temperature	0 - 50°C (32 - 122°F) (With Circulated Air)				

*The repeatability of the valves is obtained by having it tested independently on the conditions similar to its original testing.

Graphic Symbols

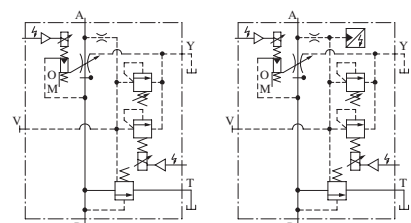

Models with Proportional Pilot Relief Valve

Models with Proportional Relief Valve and Sensor

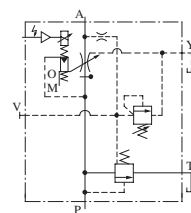

Models without Proportional Pilot Relief Valve



External Pilot Pres. Connection

■ Model Number Designation

F-	EHFB	G	-03	-60	-C	-E	-S	-50
Special Seals	Series Number	Type of Mounting	Valve Size	Max. Metred Flow L/min (U.S.GPM)	Pilot Relief Valve Pres. Adj. Range	Pilot Connection of Flow Control	Pressure Controls	Design Number
F: Special Seals for Phosphate Ester Type Fluid (Omit if not required)	EHFB: Proportional Electro-Hydraulic Flow Control and Relief Valve	G: Sub-plate Mounting	03	60: 60 (15.8) 125: 125 (33)	None: Without Proportional Pilot Relief Valve	None: Internal Pilot E: External Pilot	None: Open-Loop S: Open-Loop with Sensor	50
			06	250: 250 (66)				50
			10	500: 500 (132)	C, H: See Specifications			50